





Theme

Exemplary Description of Learning Field Concept

Performance: Mr. Fey, Mr. Weichert





Overview

- Assignment
- What is to be done?
- Competences / Skills
- Cooperation Vocational School / Company
- Comparison Model / Reality
- Learning Field Concept
- Apprenticeship

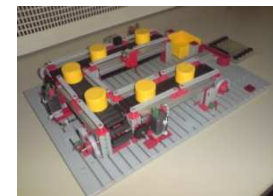



Assignment

- Implementation of a Conveyor Belt Controlling

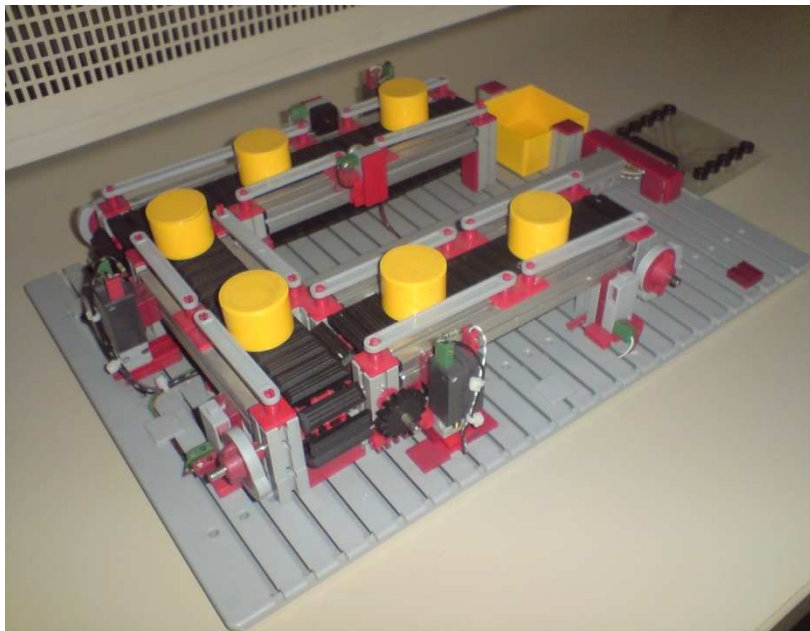

Model

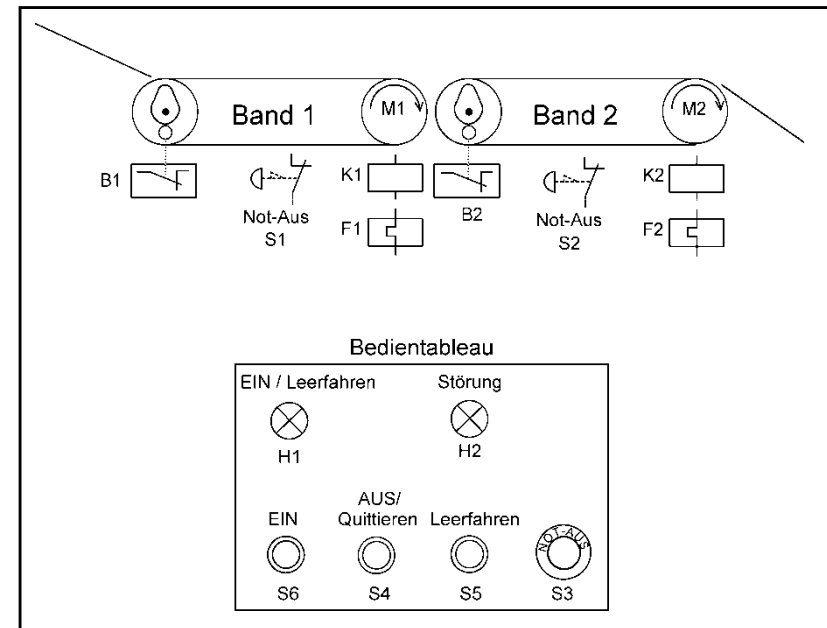

Technical Diagram



What is to be done?

1. Describing the operation mode
2. Controlling with the logo-device
3. Controlling with contactors
4. Documentation





Competences

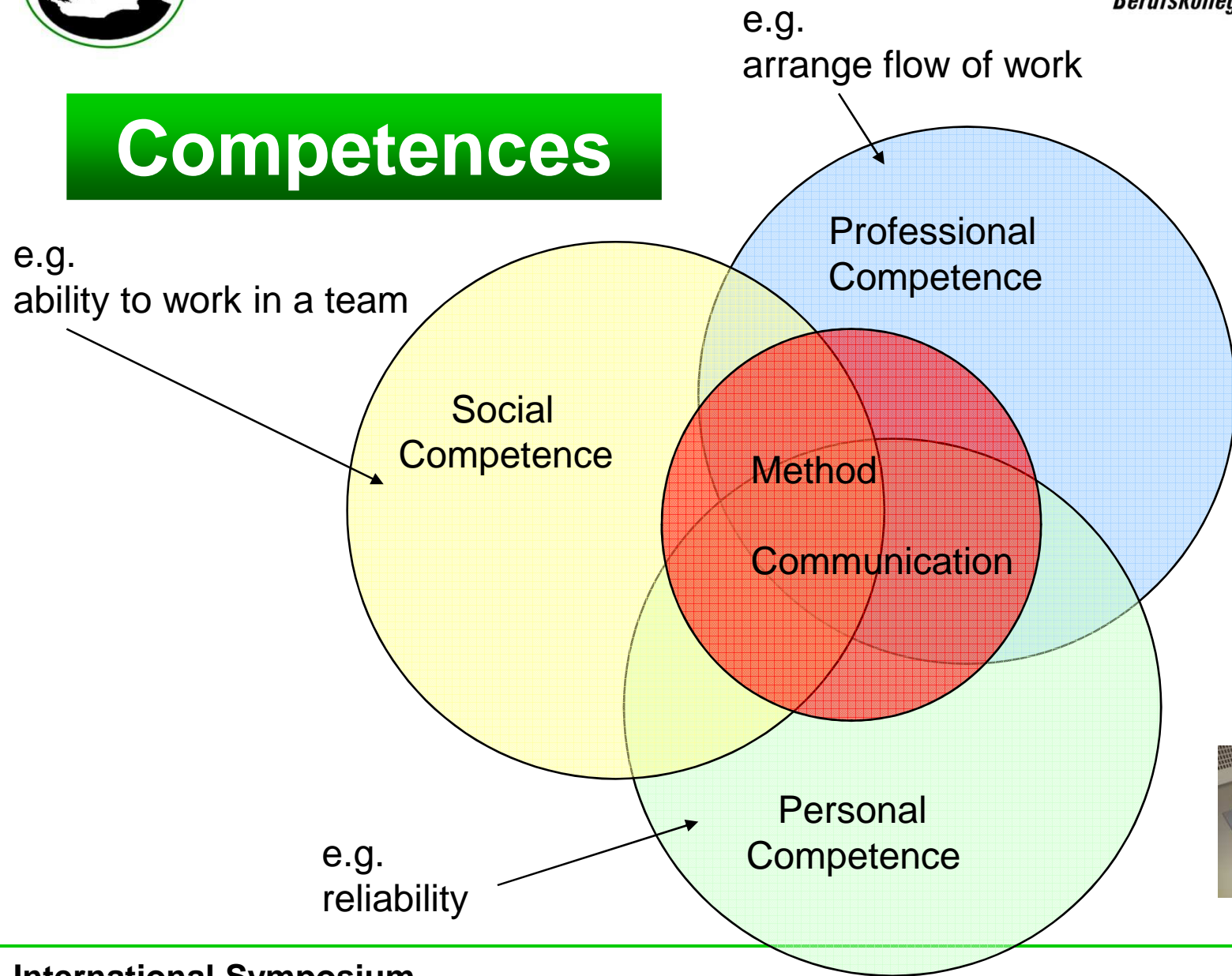



Competences / Skills

To Dos	Competences	Concept
<ul style="list-style-type: none">•...•Planning•...	<ul style="list-style-type: none">•Pupils are able before•Pupils learn ...<ul style="list-style-type: none">– to divide the problem into smaller units– ...– to combine the solutions of the smaller problems to the whole function	improve the <u>professionalism</u> and <u>method competence</u>



Cooperation School / Company

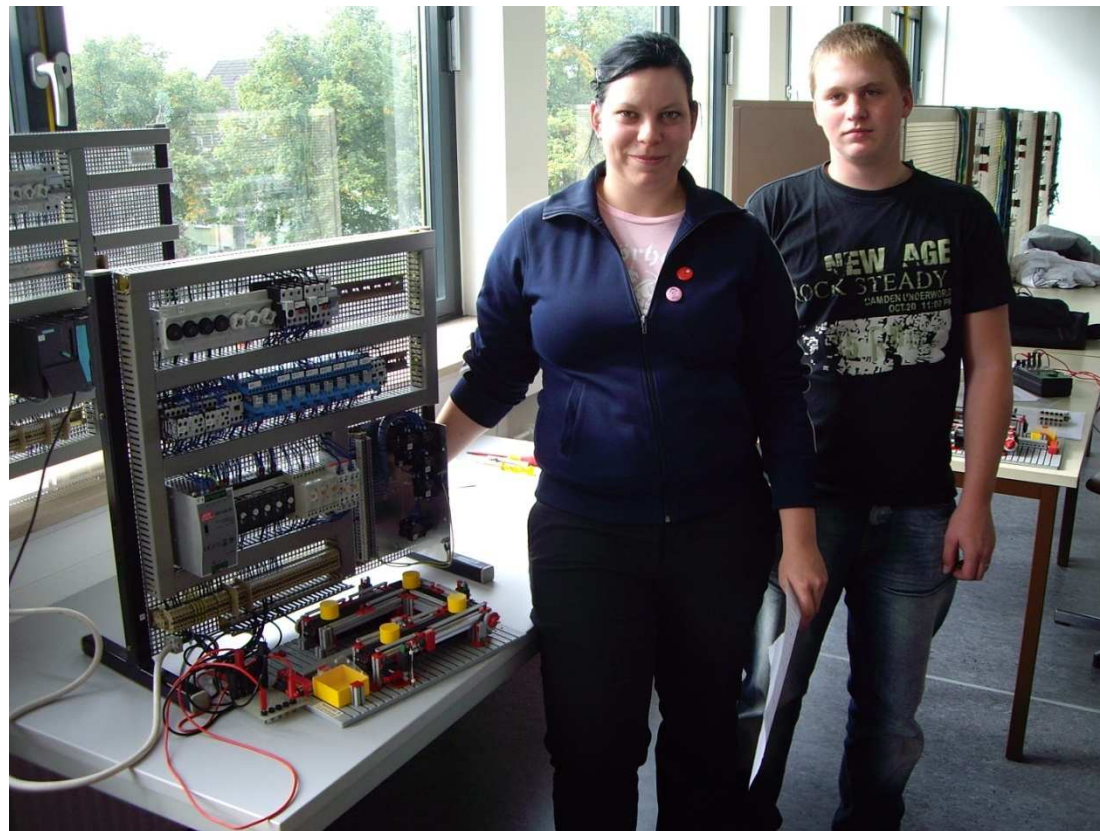

Part 2



Reality





Comparison Reality / Model



- ...
- Reading electrical diagrammes
- Delivery to the client
- Repair a failure
- Description of failure
- Build up electrical construction
- ...



- ...
- Design electrical controlling
- Delivery to the client (teacher)
- Troubleshooting
- Description of operation mode
- Connecting the electrical circuit
- ...



Learning Field Concept

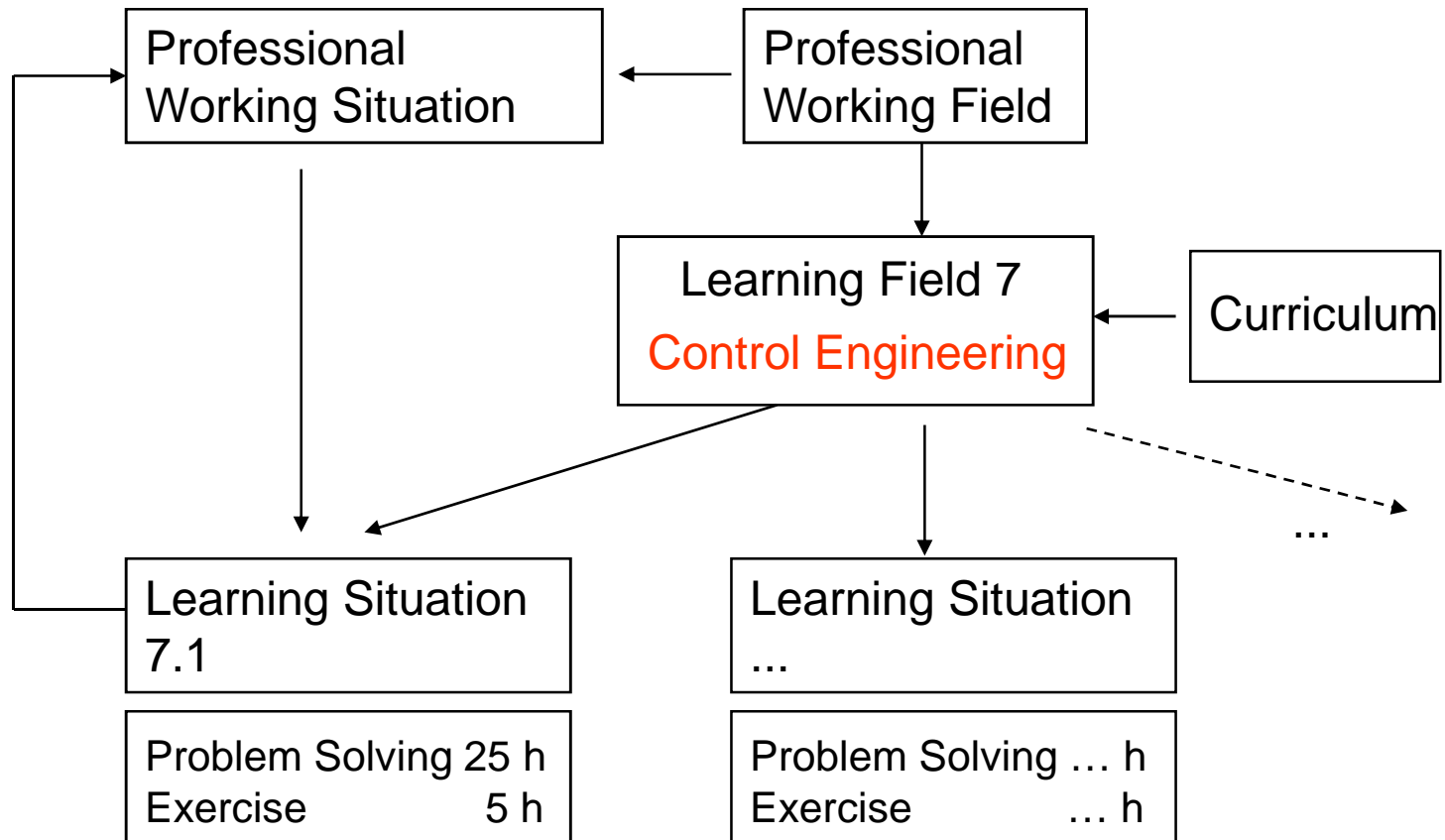



Apprenticeship

year	contents															
4																
3																
2	LS 7.3 Implementation of a conveyer belt controlling															
1																



Apprenticeship

	Control Engineering
4	...
	...
3	LS 11.1
	...
	LS 7.1
2	LS 7.2
	LS 7.3 conveyer belt
	...
1	LS 3.4
	...



Apprenticeship

4	... LS 13.2			
3	... LS 11.1 ...	LS 10.1	LS 9.1	LS 12.1
2	LS 7.1 LS 7.2 LS 7.3	LS 5.2	LS 6.1	LS 8.2
1	... LS 3.4 ...	LS 1.4	LS 2.3	LS 4.1



Apprenticeship

	electrotechnical				general	
4	...	LS 13.2				politics economy
3	...			LS 8.2	physical education	politics economy
	LS 11.1					
2	...	LS 6.1	religion English	politics economy
	LS 7.1					
	LS 7.2					
1	LS 7.3	LS 1.4	LS 2.3	LS 5.1	German	politics economy
	...					
	LS 3.4					



Apprenticeship

	school					company	
4	dark green	dark green	dark green	dark green	dark green	light blue	light blue
3	green	purple	orange	grey	yellow-green	light blue	light blue
2	green	purple	orange	grey	yellow-green	light blue	light blue
1	green	white	orange	teal	yellow	light blue	light blue

Over



Thanks for paying attention!

Geschwister-Scholl-Schule
Städt. Berufskolleg für Technik,
Hauswirtschaft und Sozialpädagogik
- Sekundarstufe II -

Bismarckstraße 207 - 209
51373 Leverkusen

Telefon : 0214 / 373-310 o. -510
Telefax : 0214 / 373311
Email : bkgs@schulen-lev.de

Schulleiter: Alfred Ansorge
Stellv. Schulleiter: Jakob Hungenberg

Kontakt EU-Koordinatoren:

Till Piontek - t.piontek@gss-lev.de

Thorsten Noelle – t.noelle@gss-lev.de

www.gss-lev.de